

Job Application

Title
Outline Drawing for:
Float Cable Suspended System

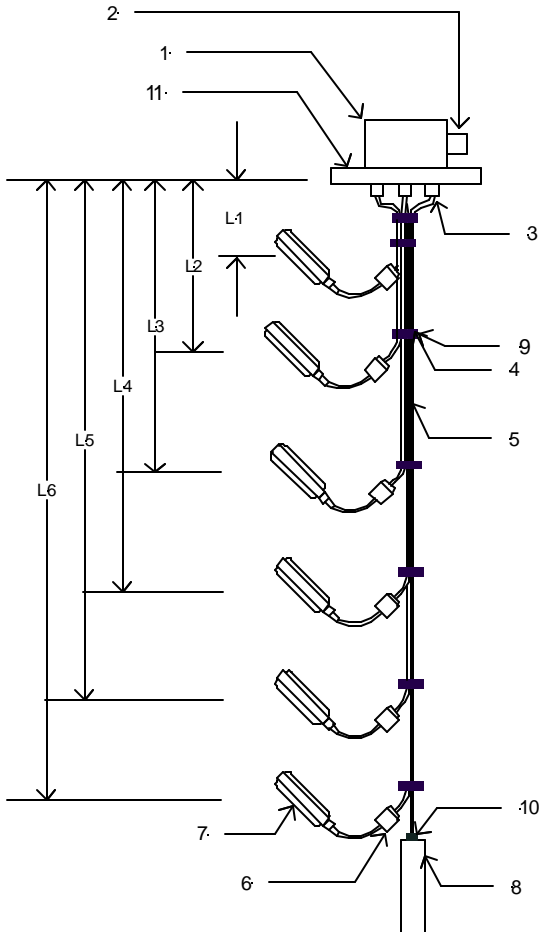

Level	Dimension	Application
.1	JN or MM	
2	JN or MM	
3	JN or MM	
4	JN or MM	
5	JN or MM	
6	JN or MM	
Special Requirements:		

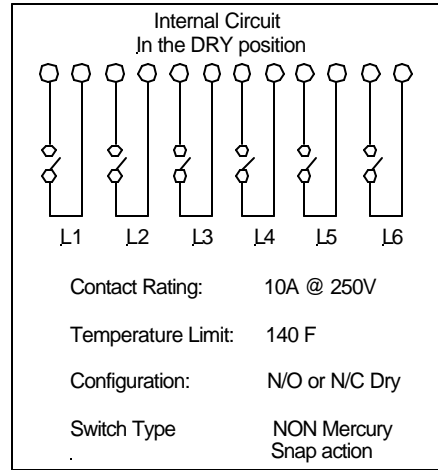

REV	DATE	DESCRIPTION	BY	APP.
REV		Special stainless horizontal cable supports Non Fray		
REV				
REV				

1	NEMA 4 J Box c/w Cable Glands	8	Weight SS .15 Pounds
2	Cable Glands	9	Tie Straps
3	Cable Strain Relief	.10	Cable Connection Stainless
4	Cable Support Non Stress SS	.11	Option- Drwaing is: 3" 316 Stainless .140# ANSI Flange
5	Cable .18-2 SJO W/A		
6	Weights Option	.12	
7	Float 3-3/16" x 5-5/32" x 1-5/8" Polypropylene	.13	

DATE	Dr. By - RJH	Multi Level Cable Ball Float Switch	
Scale - N.T.S	Ch. By:		
UNITS millimeters	App. By		
Almeg Controls		Drawing	