

Operating Instructions

For

Level Control Module

Model SSR 1000

SSR 1000 LEVEL CONTROL RELAY MODULE

1. Note

Please read and take note of these operating instructions before unpacking and commissioning. The instruments may only be used, maintained and installed by qualified personal familiar with the operating instructions and the applicable health and safety requirements.

2. Contents

1. Note
2. Contents
3. Specific Applications
4. Operating Principle
5. Instrument Inspection
6. Mechanical Installation
7. Technical Specifications
8. Electrical Connections
9. Start – Up
10. Troubleshooting
11. Maintenance

3. Specific Applications

The Level Control Module has been designed for use in level monitoring applications and pump control for liquids

The module consists of a transformer, control logic circuit and output relay

The SSR is a bi stable latching type control module with SPDT relay contacts output. Inputs should be dry (potential free) contacts, for example reed switch contacts from a float type level detector. The module generates 24VDC to detect input switch closure; the current is limited to 20 mA on the inputs, in order to protect the level switches. In addition the module has built in time delay on the inputs, which avoids false triggering due to switch bounce or nuisance tripping from process vibration, waves or bubbles.

4. Operating Principles

The module is designed to provide detection of two levels in a process tank and control the tank level in either a pump-up or pump-down mode of operation.

Pump-Up Mode

In a pump up mode, the relay will initiate by switching the pump when the fluid level in the tank falls below the lower tank level switch. The relay will remain energized (latched) and the pump will continue to operate until fluid fills the tank up to the high level switch. When the fluid reaches the high level switch the control relay will de-energize and shut off the pump. The control module relay will remain de-energized until the fluid falls below the low tank level switch.

Pump-Down Mode

In a pump-down mode, the relay will imitate by switching on the pump when the fluid level in the tank reaches the upper tank level switch. The relay will remain energized (latched) and the pump will continue to operate until fluid inn the tank empties down to the low level switch. When the fluid falls below the low level switch the control module relay will de-energize and shut off the pump. The control module relay will remain de-energized until the fluid reaches the high level switch.

SSR 1000 LEVEL CONTROL RELAY MODULE

5. Instrument Instructions

The instruments are thoroughly inspected by the factory prior to shipment and sent in perfect condition. Should any damage to the device be visible, we recommend a thorough inspection of the delivery packing. In case of damage please inform your parcel service/forwarding agent immediately, since they are responsible for damages incurred during transit.

Scope of delivery:

- Level Control Relay Module
- Operation Manual

6. Mechanical Installation

The relay module enclosure is rated IP 20 (approx. equivalent to NEMA 1), which is intended for use in dry, dust free environment. If the relay module will be located in harsh, wet or dusty environments, the user should mount in an appropriate enclosure to protect the device. For example - NEMA 4X electrical enclosure.

The relay module can be mounted on to a standard DIN mounting rail, according to DIN 46277, EN50022. The device snaps on to the DIN rail and can be removed from the rail by releasing the spring-loaded clip, located on the bottom of the device.

Drawing Pending

SSR 1000 LEVEL CONTROL RELAY MODULE

7. Technical Specifications

Preliminary Technical Data Sheet

Instrument Type	Electromechanical Contact Protection Relay
Model	SSR 1000
Housing Size	75mm x 50mm x 100mm
Housing Material	Polyamide 6.6
Supply Voltage	115 VAC +/- 10% 50 – 60 Hz
Power Consumption	5 VA (typical)
Control Voltage	24 VDC
Control Current	20 Ma
Input Impedance	3300 Ohm, 100 nF +/- 20%
Maximum Contact "ON" Impedance	4700 Ohm, 47 nF at inputs
Delay Period (initiating)	10 ms
Delay Period (dropping)	20ms
Output	1 SPDT relay contact
Permissible Load	250 VAC / 8A resistive / 1840 VA
Temperature range	-20 deg. C to 60 deg. C
Type of protection	IP 20

SSR 1000 LEVEL CONTROL RELAY MODULE

8. Electrical Connection

ATTENTION: Ensure that the voltage levels of your supply system are in agreement with the voltage levels given on the Type Label of the device.

- Make sure that the electric supply lines are not active during connection to this device.
- Improper wiring can lead to damage of this device as well as injury to the user.
- Make sure that installation; wiring and circuit protection are in **accordance with all local electrical codes.**
- Make sure the supply circuit **provides adequate fuse or circuit breaker protection** that is in accordance with the circuits current rating.
- Make sure that a **motor contactor relay or starter is used to energize the pump circuit, if the pump current rating exceed the SSR 1000 Level Control's relay rating.**

Electrical connections to the relay module are made by - connecting the wires to the numbered screw terminals. Wiring is per attached drawings and specifications.

Wiring Table

Terminal #	Description	Function
A1	Mains Connection	Connect to 115 VAC Supply
A2	Mains Connection	Connect to Mains Neutral Supply
12	Sensor Input Common	Connect to one side of switches
13	START Input	Momentary Closure of 12 and 13 Energizes Output Relay (latched)
11	STOP Input	Momentary Closure of 12 and 11 DE Energizes Output Relay (Reset)
42	Relay Output Common	Common Wire
41	Relay Output N/C	Normally Closed Contact – When Relay Energized 42 and 41 Open
43	Relay Output N/O	Normally Open Contact - When Relay Energized 42 and 43 Close
82 & 81	24 VDC Excitation	Sensor Supply Maximum 20 mA

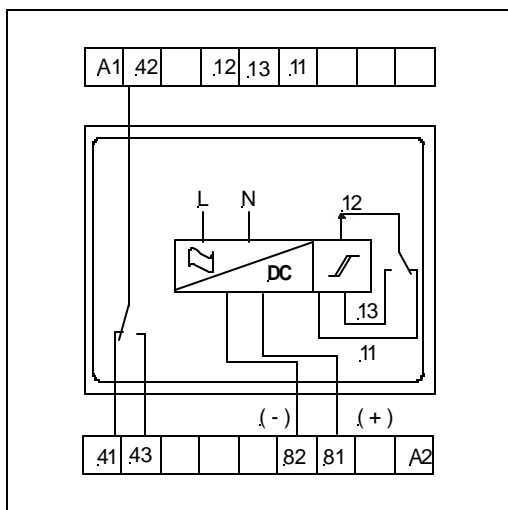

SSR 1000 LEVEL CONTROL RELAY MODULE

Start & Stop
Hi and Low-level Contacts
Located on Tank

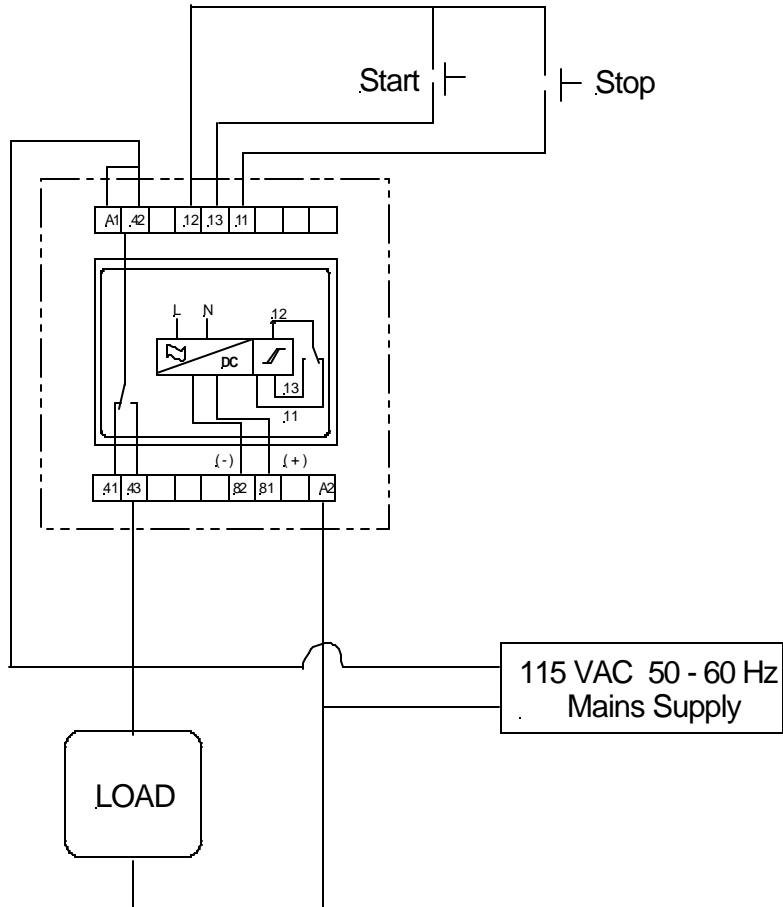

NOTE: When using multi level or side mount switches

Pump-Up Application:

Start = Bottom Position N/C Dry

Stop = Top Position N/O Dry

Pump-Down Application:

Start = Top Position N/O

Stop = Bottom Position N/C Dry

Recommend including backup safety switches

Example Hi Alarm for overflow protection

In the event of pump or circuit failure

Wiring Diagram for Pump Control

SSR 1000 LEVEL CONTROL RELAY MODULE

9. Start-Up

Ensure that all wiring to the Level Control Module is correctly installed and the level switches are installed and functioning correctly. The Relay Module is now ready for operation and the supply power to the level control circuit can be applied. Depending on whether the module is wired for pump-up or pump-down mode of operation, the relay should operate in accordance with the description in section 4. Operating Principals.

10. Troubleshooting

The relay does not operate:

- Check the mains voltage is applied to the L and N terminals on the module.
- Check that there is 24 VDC across terminals 82 and 81. If mains voltage is applied and no 24 Volts is measured across 82 and 81 the module may be defective.
- Check level switch operation and cabling from the tank location to the module. Temporarily remove the switch inputs from the module and simulate level switch closure using jumper wires across input terminals. (this is a latching relay - so test as such)
- When simulating level switch closures, the relay does not activate, the relay may be faulty.
- If the relay activates but does not start the pump, the output wiring circuit may be faulty.

11. Maintenance

The Level Relay Module requires absolutely no maintenance. Depending on the type of level sensors used and the process conditions, maintenance to the sensors may be required. Verify and follow maintenance procedures according to the sensor maintenance manual. Verify and follow maintenance procedures according to the pump or solenoid manufacturer's maintenance manual.

There are no user serviceable parts inside the SSR 1000 module. If repair is required please contact your local distributor to return for repair.

Your Distributor Is

